



# PCB Depanelizer

## Operation Manual



### Notes

- \* Before using the machine, please read this manual carefully, and it will help you operate it smoothly.
- \* Do not remove the guard around the blade under any circumstance, in order not to cause any danger
- \* The machine is only designed for circuit board with pre-scored V-cut, do not use in other purposes.
- \* When operating this machine, do not wear too loose clothes. Long hair should be tied up to prevent it from being entangled.

## 1,Parts name of the machine (see Figures 1 and 2)

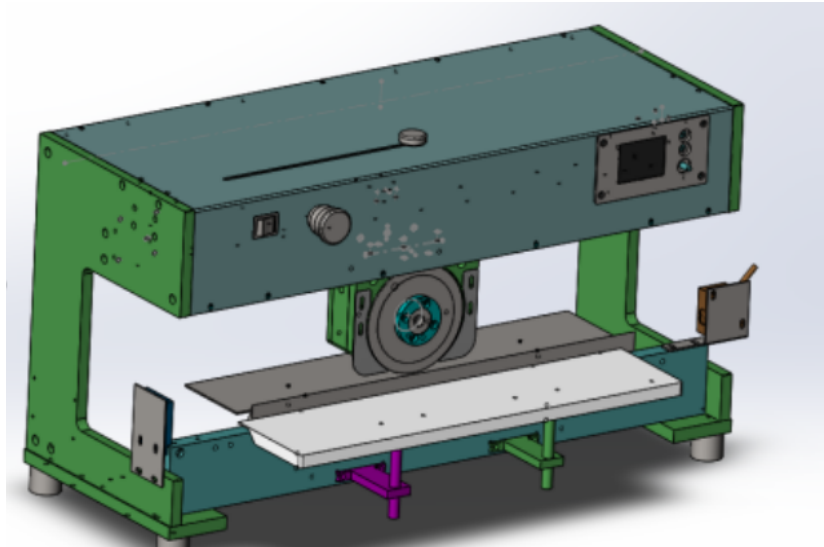

Figures 1

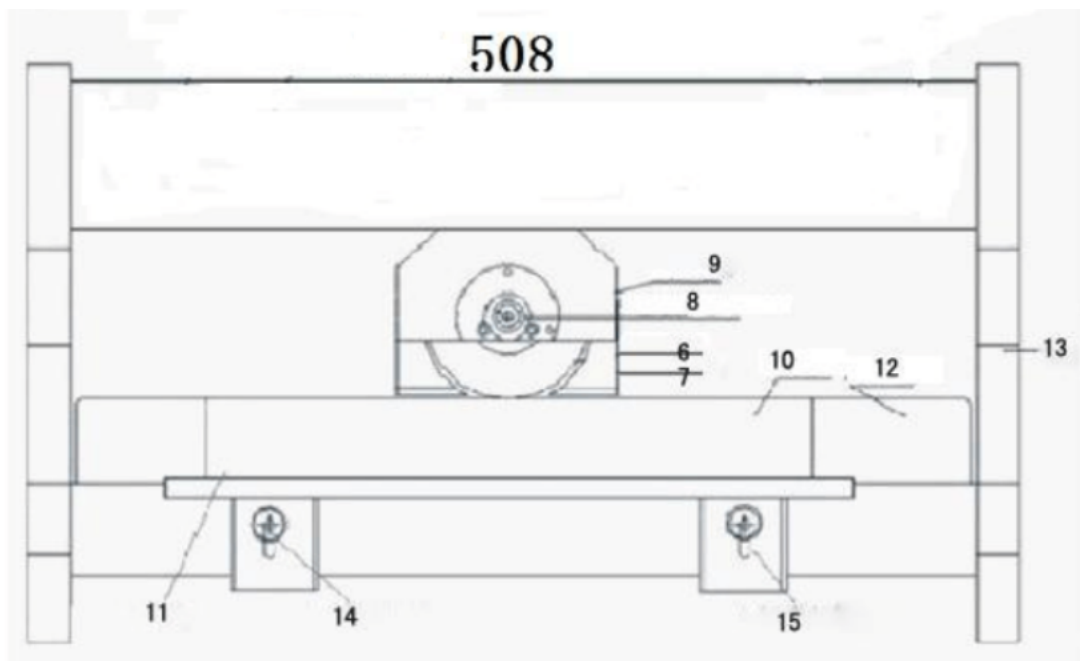

Figures 2

- |                                   |                                      |                                   |
|-----------------------------------|--------------------------------------|-----------------------------------|
| 1. Plate mode tuning knob         | 7. Guard of upper blade              | 13. Side panel                    |
| 2. Power indicator and the origin | 8. Height tuning knob of upper blade | 14. Manual knob screw             |
| 3. Plate trip button              | 9. Upper blade seat                  | 15. Height limiter of upper blade |
| 4. High/low speed switch          | 10. Lower blade                      |                                   |
| 5. Emergency stop switch          | 11. Outer tray                       |                                   |
| 6. Upper blade                    | 12. Guard of lower blade             |                                   |

## 2, Technical indicators

Maximum plate length: 360 (or option 500mm)

Thickness of plate: 0.2-5.0mm

Plate feeding speed: 300-500mm/ second

Blade material: SK61D high speed steel

Operating temperature: 10-35 °C Storage temperature: -20-50 °C

Power supply: 230V/110V, 50HZ/60HZ, 40W

Dimension: 600mm\*395mm\*425mm

Weight: 37KG

## 3, Preparation before installation and use of the machine

1. Check the objects in the packing box, including the following parts: host, manual, power wire, pedal switch and hexagonal wrench for tuning.
2. Remove the packing bag of the machine, place it onto the solid work bench, and wipe antirust grease on the blade.
3. The machine must be reliably earthed to prevent the damage by static electricity to the components on the circuit board. If the ground in the power socket is reliable and effective, the machine will be reliably earthed once it is powered.
4. Fix the outer tray (11) to the machine with two fixing screws, adjust the height of the components on the circuit board to adjust it to a suitable height, and manually lock the tray knob screw.
5. Plug the pedal switch into the corresponding socket at the back of the machine, to ensure the supply power is correct before powered.

## 4, Adjustment of machine

1. Ensure the components on the circuit board will not collide with the body and blade. See Figure 1 for the dimensions of the machine. The height of the components on the circuit board will not exceed the scope. If the components on the circuit board touch the blade, contact us to pre-process the blade to avoid the cutting of components.
2. According to the thickness of the circuit board, adjust the height of the upper blade by adjusting the knob.

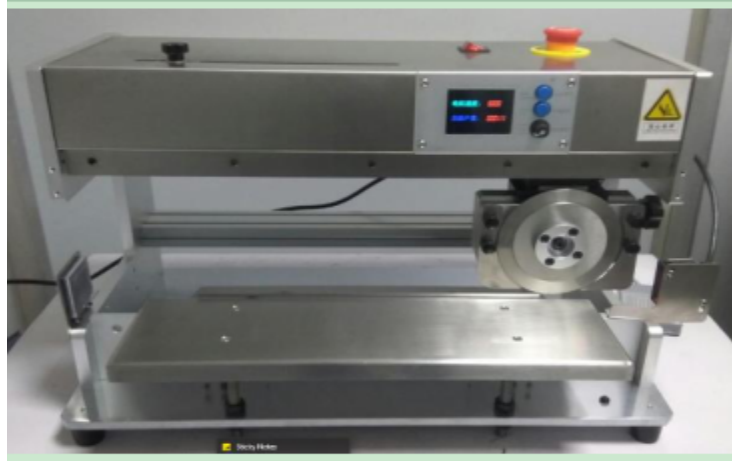

Figures 3

## 5, Daily maintenance of machine

During the use of the machine, the maintenance work is quite simple. Keep the machine clean, and paint the anti-rust grease on the upper and lower blades on a regular basis. Designate a person responsible for the operation and maintenance, to ensure the machine precision. Do not use or store it under high or low temperature (see Section 3).

## 6, Replacement of the blade

After long use of the machine, if the blade is damaged, loose the adjusting knob screw (16), to remove the damaged old upper blade; if the lower blade is damaged, remove the inner tray (13), loose the four screws on the lower blade, to remove the damaged old lower blade.

### 6.1, Operation instruction

6.1.1, Connect to the power supply and start the switch. Indicator lights 0 and 400/600 flash, press the button corresponding to the flashing light, the light will on continuously. Press the foot switch, and the upper blade will return to the origin and can move between 0 - 400/600. Touch key 0 or key 400/600 to allow the indicating light to flash, and touch 100/150. 200/300. 300/450. Any key can allow the corresponding two lights to make them on constantly, then the upper blade travels between these two lights and the upper blade can travel between any points of 0-400/600.

6.1.2, Adjust the gap between the upper and lower blades, generally between 0.1 and 0.2. The gap between the upper positioning blade and lower positioning blade is generally equal to the thickness of PC board.



6.1.3 The upper and lower cutters must be in the same plane, and the error cannot exceed 0.1mm.

6.1.4, Adjusting method of eccentric distance

6.1.5, The working platform can be adjusted upward or downward.

6.1.6, Set the cutting travel and speed, and setting method shall follow the adjustment method mentioned above.

6.1.7, Step on the pedal switch, and try sometimes. In case of no abnormity, formal work can be started.

## 6.2, Basic maintenance

6.2.1. After the completion of the work, please turn off the power supply and remove scraps.

6.2.2. Pay attention to the protection of upper and lower cutters.

6.2.3. When the machine is out of work for a long time, please remove the upper and lower cutters and coat with oil to protect. Please wipe it before use.

6.2.4. Pay attention to checking the fastening of all screws

## 6.3, Straight knife disassembly steps

As shown in (Figure 4), remove the four M5 screws below the cutting platform counterclockwise with a 4MM hexagonal wrench, and then remove the cutting platform.

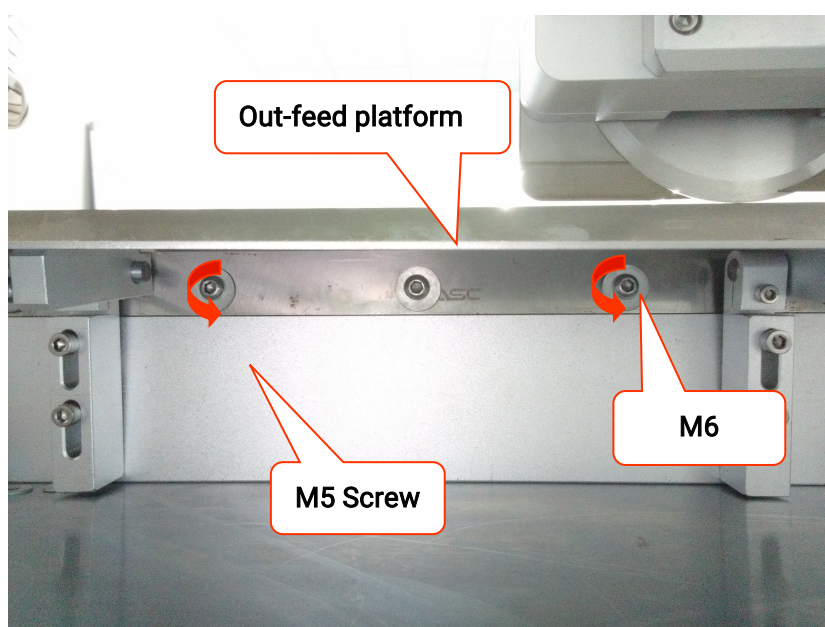

Figures 4

Then loosen the five M6 screw above the straight knife counterclockwise with a 4MM hexagonal wrench to remove the straight knife.



Figures 5

## 6.4, Round knife disassembly steps

6.4.1. As shown in (Figure 6), the four black screws shown in the figure are loosened counterclockwise to remove the guard knife.

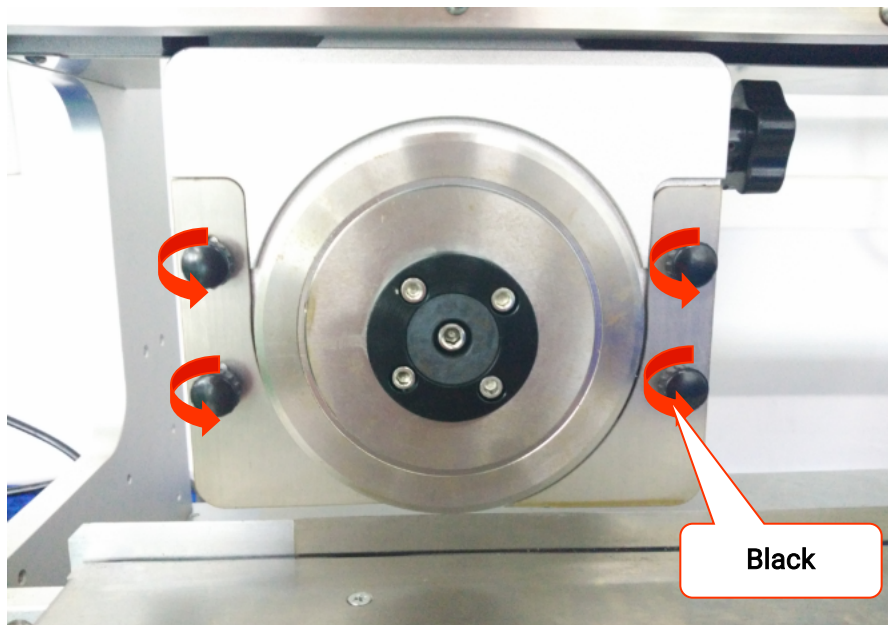

Figures 6

As shown in (Figure 7), fix the M6 screw in the center of the spindle with a 5M M hexagonal wrench, and then remove the four M5 screw in turn counterclockwise with a 4M M hexagonal wrench. Finished like (Figure 8).



Figures 7

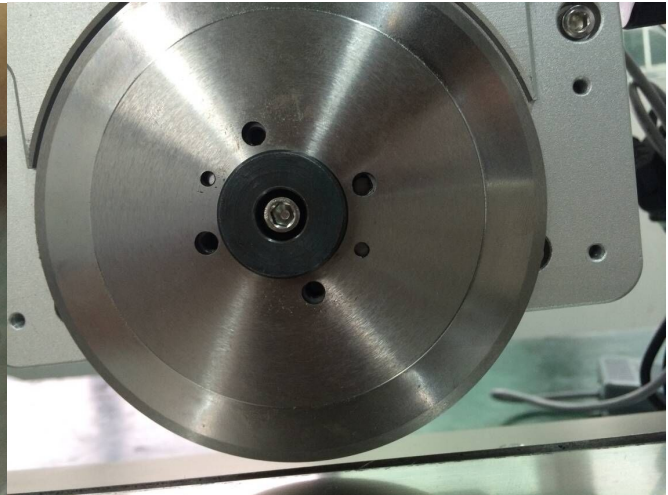

Figures 8

## 7,Explanation of S-D508/509 Speed Regulation

Generally speaking, the machine has been adjusted to cut the board by pressing the foot switch. To adjust the segmentation speed, follow the following steps (all pictures are displayed after each step):



7.1. Press the speed adjustment button and turn the white number of the motor speed column on the screen into blue, then proceed to the next step.

7.2. The speed knob rotates to adjust the speed of the motor, which corresponds to the cutting speed, and the maximum value is in the range of 70.

Speed adjustment button press the blue number again and turn it into white number to confirm saving.

## Warranty Card

Name of user:

\_\_\_\_\_

Address of the user:

\_\_\_\_\_

Type of machine:

\_\_\_\_\_

Telephone of user:

\_\_\_\_\_

Date of purchase:

\_\_\_\_\_

Seal of the dealer:

User instructions:

\_\_\_\_\_

I. Warranty 1 year for the machine since the date of purchase, and lifetime maintenance.

II. The following situations are not covered under warranty:

- (1) The machine is damaged due to the improper operation, negligent use or natural disasters.
- (2) The components of the machine fail due to the abnormal operation.
- (3) The machine has been disassembled or repaired by the people other than the technical personnel of the company.
- (4) The damages are due to the consumables or parts not provided by the company.
- (5) The damages are due to the use of the voltage not prescribed by the company.

III. In addition to the warranty, the company will not recognize the warranty card issued by any other enterprise or person.

IV. Please well keep this card and the formal purchase receipts, and render them to the company's personnel for review. Then the card and receipts are valid.

V. If the card contains no business seal or date of purchase, it will be deemed as invalid.